



Cogeneration Analysis

**Metropolitan Healthcare Complex
Grand Rapids, MI**

Prepared By:
William Ryan
John Cuttica
Leslie Farrar
Clifford Haefke



The University of Illinois at Chicago
Energy Resources Center
851 S. Morgan St, SEO, 12th Floor,
Chicago, IL 60607-7022
(312) 996-4490



Executive Summary

An analysis of the potential for B CHP system at the Metropolitan Hospital facility and Metropolitan Hospital Campus has predicted that the following B CHP option will be best suited for these applications.

Generator Type	Reciprocating Engine
Generator Size	2,750 kW and 4,000 kW
Number of Generators	1
Heat Recovery System	Heat Exchanger
Uses of Heat	Space Heating, Hot Water, Absorption Cooling
Operating Strategy	Electric Rate Following
Purchased Energy Strategy	Utility Electric, Gas Contract
Operating Cost Savings Projection	\$260,000 /yr and \$399,000 /yr
Installed Cost Projection	\$2,258,000 and \$2,926,000
Simple Payback	8.7 yrs and 7.3 yrs
Internal Rate of Return	NOT COMPLETED



Table of Contents

Executive Summary	3
Table of Contents	5
Economic Analysis	9
Assumptions.....	9
Model Description	11
Model Results	13
Background of BCHP Systems.....	19
BCHP System Benefits	21
Reduced energy costs.....	21
Improved Power Reliability.....	21
Improved Economics for Enhancing Indoor Air Quality	22
Reduced Life-Cycle Costs	22
Attractive Return on Investment.....	22
BCHP Technology	23
Power Generation Equipment.....	23
Combustion turbines	23
Engines.....	26
Power Generation - Installed Costs.....	28
Fuel cells	29
Productively Using Waste Heat - Thermally Activated Equipment.....	32
Absorption chillers.....	32
Desiccant dehumidifiers.....	35

Introduction

This report is divided into two sections.

- The first is an investment analysis on adding a cogeneration system to your facility.
- The second section is information on cogeneration technologies and contains descriptions and manufacturing contacts for the various types of equipment involved.

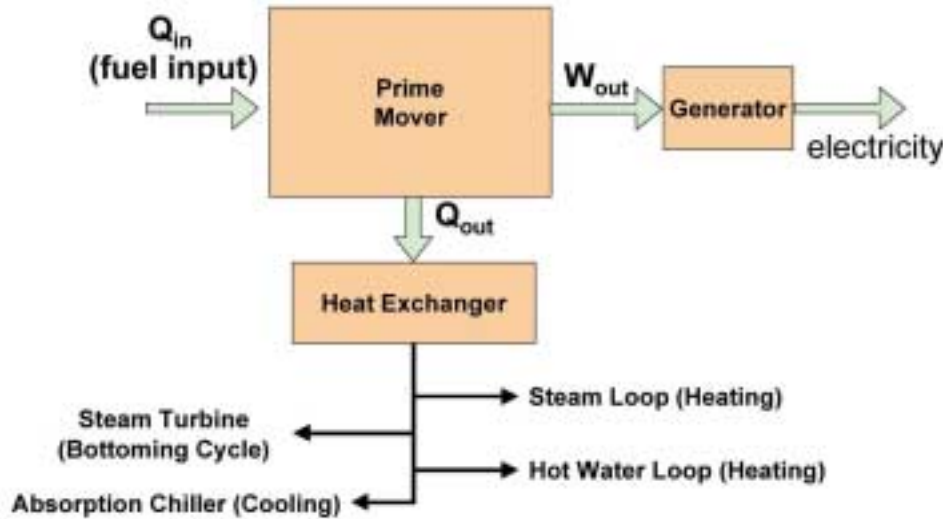

Figure 1: What is Cogeneration?

Cogeneration is the Process of Generating Power at Your Site and Using the Waste heat for Heating and Cooling. A cogeneration system generally involves generating power or work (shaft output) from a prime mover (engine, turbine, or fuel cell) and recovering the waste heat from the prime mover to deliver space heating, hot water, and/or space cooling.

Facility Description

The future facilities being reviewed are a 1,000,000 square foot hospital and a 1,400,000 square foot hospital campus in Grand Rapids, Michigan. The proposed building projects are heated by steam boilers and cooled by electric chillers. The gas and electric consumption of the facility is as shown in the next section.

Description of the Electrical and Thermal Loads

The following information on Metropolitan Hospital was taken from sample building loads run through the GTI Building Energy Analyzer program.

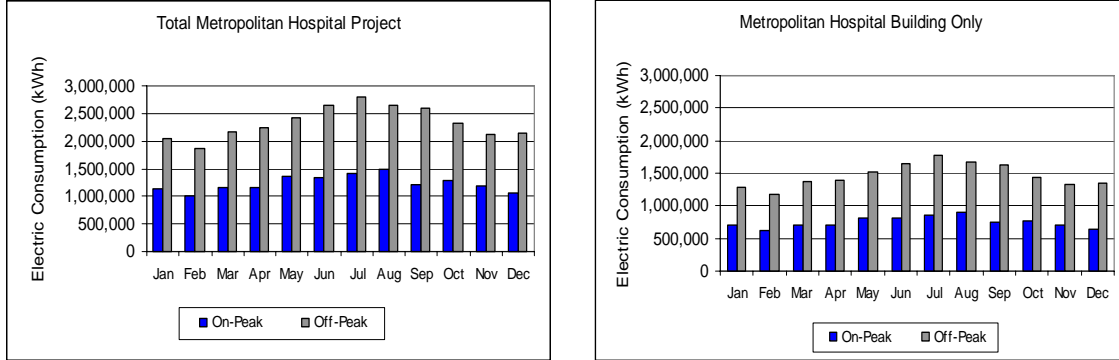

Figure 2: Electrical Consumption

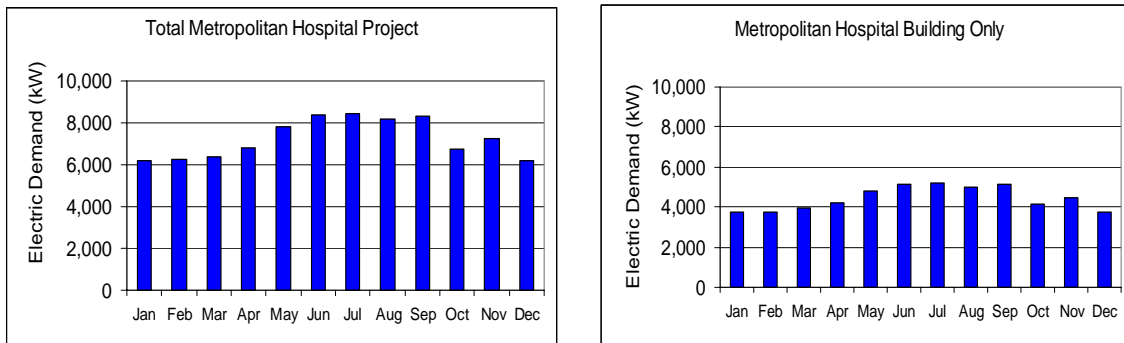

Figure 3: Electrical Demand

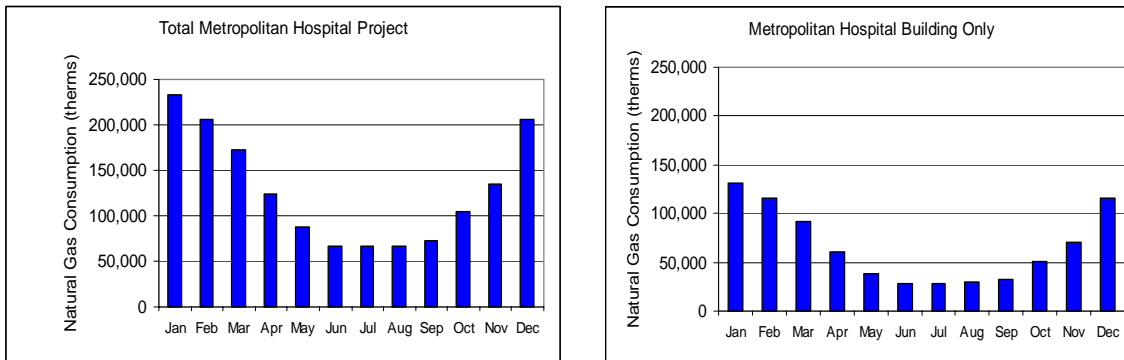

Figure 4: Current Gas Consumption and Usage

Economic Analysis

Assumptions

Economic Specifics	
Gas Rate	\$0.40/therm
Electric Rate	Grand Rapids MichCon
Maintenance Cost Allowance	\$100/mo. Plus \$0.011/kWh Included
Standby Charges	Standby Charge on Entire Capacity Included
Equipment Specifics	
Generator Type	Reciprocating Engine
Generator Operating Schedule	On-Peak Only
Heat Recovery Method (CHP and BCHP only)	Hydronic HR Boiler
Recovered Heat Applications (CHP and BCHP only)	Space Heating/Hot Water
Other Space Heating Sources	Hydronic HR Boiler
Heat Delivery Used (CHP and BCHP Only)	Hydronic System
Cooling System on Recovered Heat (BCHP Only)	Absorption Cooling
Cooling Delivery	Absorption Cooling
Other Space Cooling Sources	Centrifugal Chiller

Table 1: Assumptions Used in the Modeling

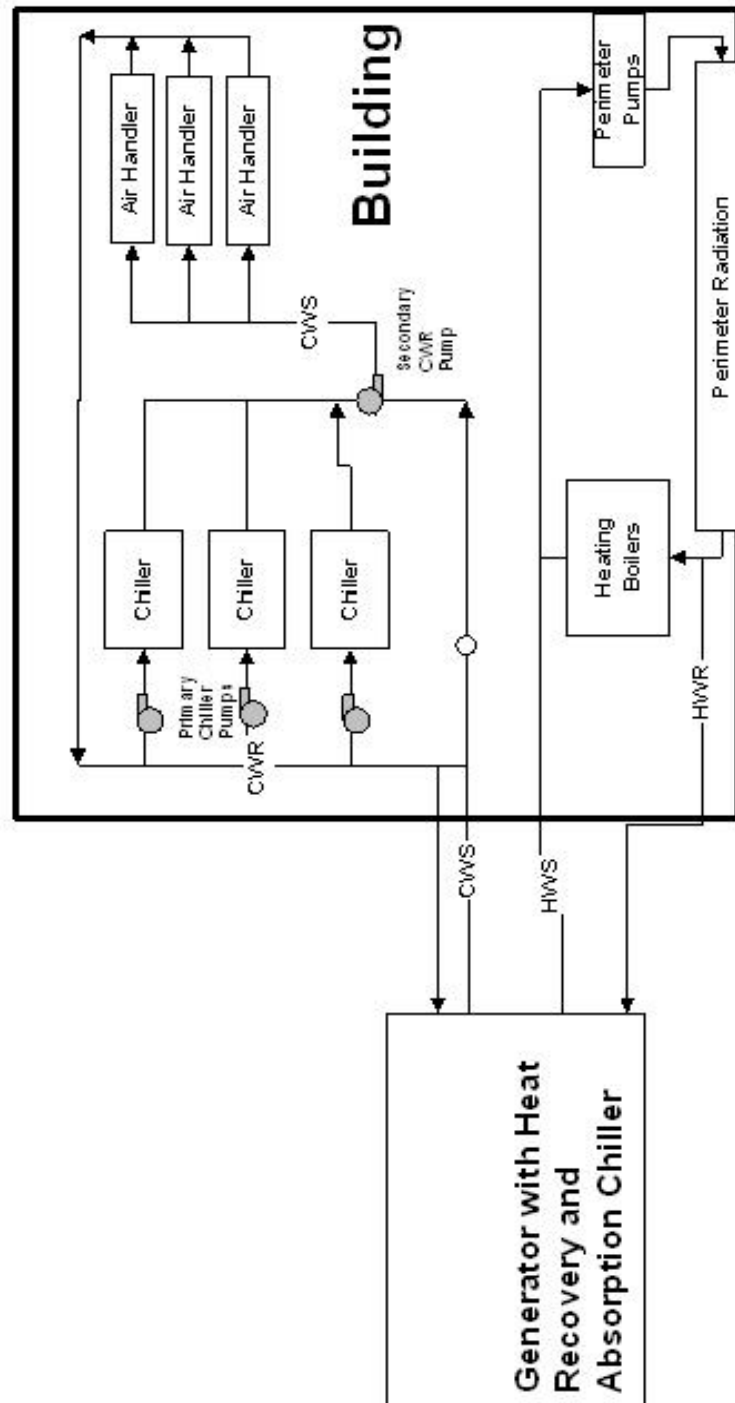

Figure 5: System Modeled for Large Building

Model Description

An hour-by-hour simulation model was developed that, for each hour of the year:

1. Uses a specific realistic generator set, including part load performance of power generation and heat recovery, which follows the electric load. This generator operates whenever the load exceeds the generators minimum output and runs at full capacity whenever the load exceeds the capacity of the generator. No sell back of electricity to the utility is assumed. In addition, the generator may be free to run as needed or may be run only during peak power periods or during electric energy/demand peak hours only, as desired. The examples used in this paper are for Chicago. Because electricity for large commercial applications sells in Chicago for approximately 2 cents per kWh off peak, the generator availability hours were set from 9 AM to 10 PM for all evaluated cases.
2. As calculated for each hour, rejected heat is passed from the generator to a single stage absorption chiller, if cooling load is present, then to the space heating load and the domestic hot water load. Heat remaining is rejected.
3. Absorption chiller is sized to match the recoverable heat from the power generator at full load. Only a portion of the recoverable heat, at temperatures higher than the minimum required to drive single stage absorption, is used to size and drive the chiller.
4. If thermally activated absorption cooling is present, the electric load reduction due to this cooling systems operation is calculated, the electric load reset, and the calculation iterates until a solution is found for that hour. Realistic characteristics are used to model the absorption and the electric chiller rating point and part load performance.

Once the entire year has been calculated and the hourly gas and electric energy consumption values are found, the operating costs are calculated from location specific energy rates. Operating savings are established by calculating the operating cost of the basic load, without generation equipment of any kind, and comparing results.

Model Results

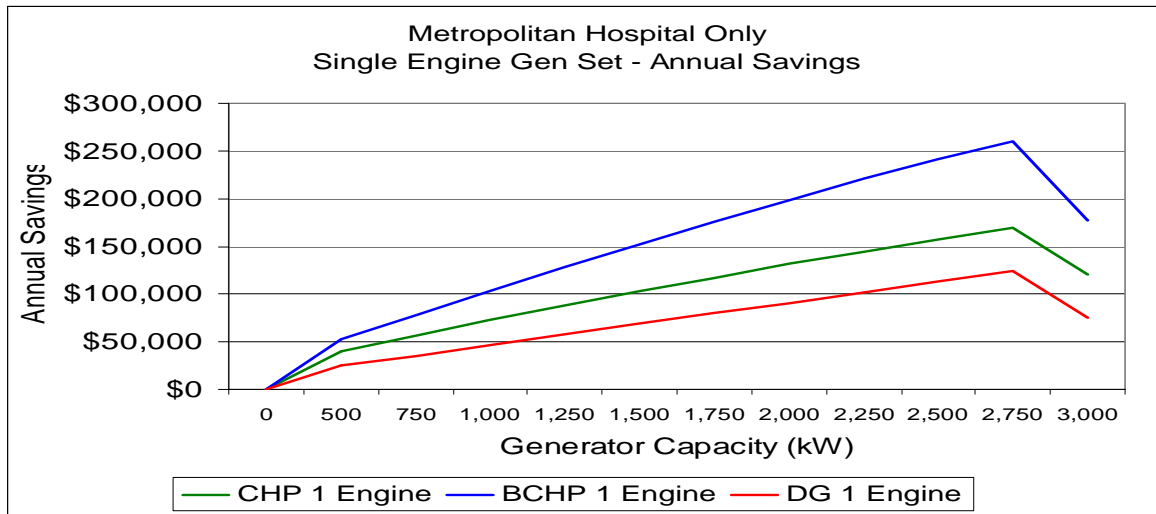

Figure 6: Cost Savings versus System Size for Hospital Building Only – One Engine

For Simple Generation System (DG), for a Generator Using the Recovered Heat for Heating and Hot Water Load (CHP), and for a Generator Using the Recovered Heat for the Heating, Hot Water Load, and Cooling Load (BCHP). The optimal economic generator sizing point for BCHP on this graph is 2,750 kW.

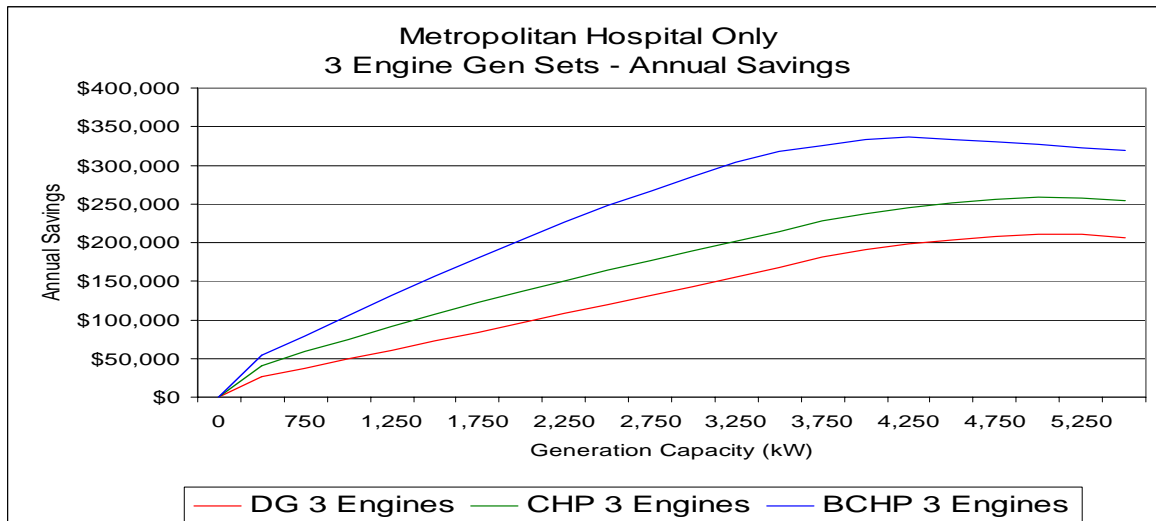

Figure 7: Cost Savings versus System Size for Hospital Building Only – Three Engines

The optimal economic generator sizing point for BCHP on this graph is 3,250 kW. (Three 1,083 kW Engines)

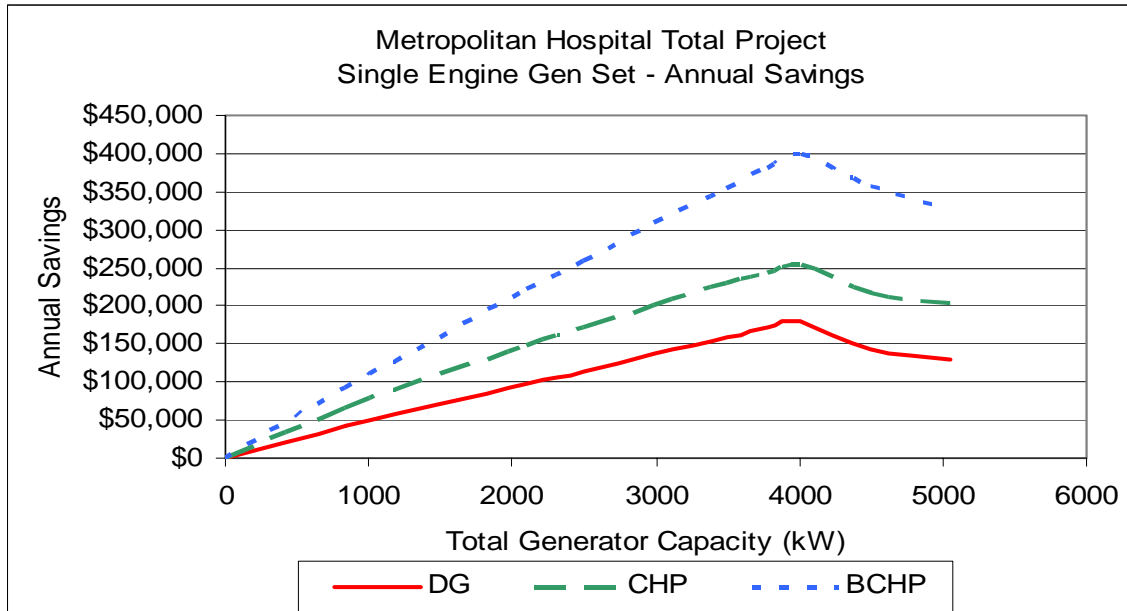

Figure 8: Cost Savings versus System Size for Hospital Campus - One Engine

The optimal economic generator sizing point for BCHP on this graph is 4,000 kW.

Definitions for the terms in Figures 8 – 11 are:

DG (Distributed Generation) = A generation only system in which the waste heat from the generator is rejected and not used

CHP (Combined Heat and Power) = A system in which waste heat from the generator is used to meet any space heating and water heating loads that exist when the generator is running. All remaining heat is rejected. Heating loads not met by recovered heat are served by the conventional heating system

BCHP (Buildings Cooling, Heating and Power) = A system in which waste heat from the generator is used to meet both heating and hot water loads as well as cooling loads via thermally driven cooling, generally an absorption chiller.

1. Heat is utilized first to meet any cooling loads;
2. If heat remains, heat is utilized to meet any heating loads;

3. If any waste heat remains after that, it is rejected.

Cooling loads not met by recoverable heat are served by the conventional cooling system.

Heating loads not met by recovered heat are served by the conventional heating system

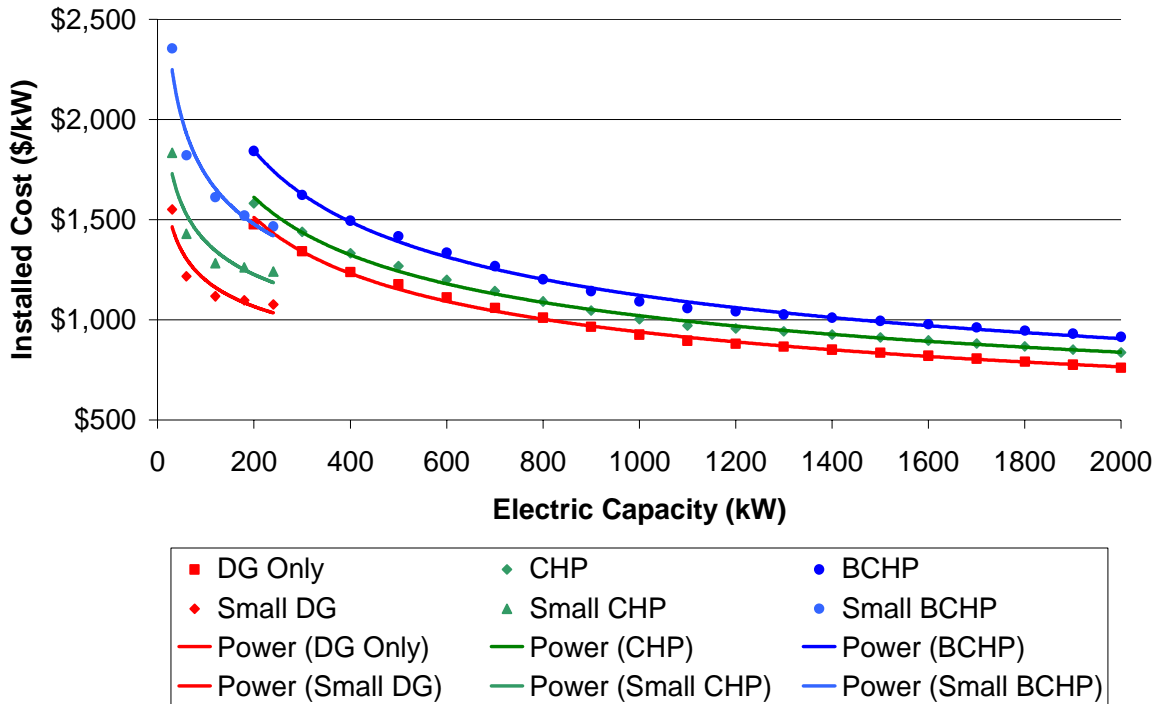

Figure 9: Installed Costs

For Simple Generation System (DG), for Using a Generator and Recovered Heat for the Heating and Hot Water Load (CHP), and for a Using a Generator and Recovered Heat for the Heating, Hot Water Load, and Cooling Load (BCHP). The installed costs per kilowatt per system are shown in chart. (The information shown in the chart helped provide initial analysis in selecting the current sized BCHP system configuration in the Executive Summary. This chart does not represent data for the current 2x400 kW BCHP system.)

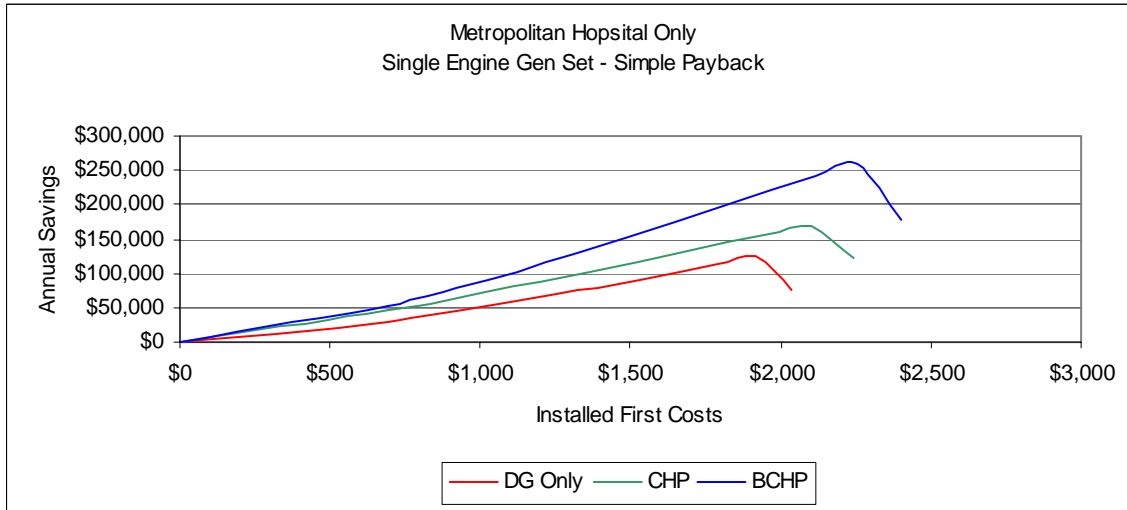

Figure 10: Iso Payback Analysis - Hospital Only, Single Engine

For Simple Generation System (DG), for Using a Generator and Recovered Heat for the Heating and Hot Water Load (CHP), and for a Using a Generator and Recovered Heat for the Heating, Hot Water Load, and Cooling Load (BCHP). The Installed First Costs versus the Annual Savings. The optimally sized system is at the point of \$2,258,000 installed first cost outputting annual savings of \$260,000. The payback of an installed generator of 2,750kW is 8.7 years.

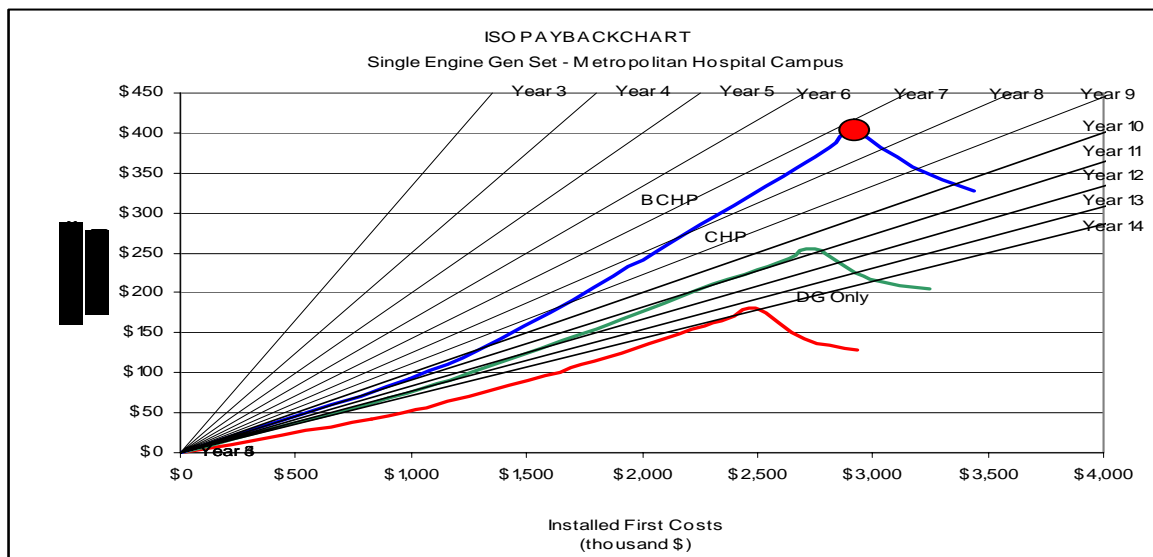

Figure 11: Iso Payback Analysis - Hospital Campus, Single Engine

The optimally sized system is at the point of \$2,926,000 installed first cost outputting annual savings of \$399,000. The payback of an installed generator of 4,000 kW is 7.3 years.

Background of BCHP Systems

The following sections in this report provide an overview of BCHP principles, technology, and benefits.

Energy is the most significant driving force of our economy. All buildings need electric power for lighting and operating equipment and appliances. One of the major consumers of energy in buildings is for cooling, heating, and humidity control.

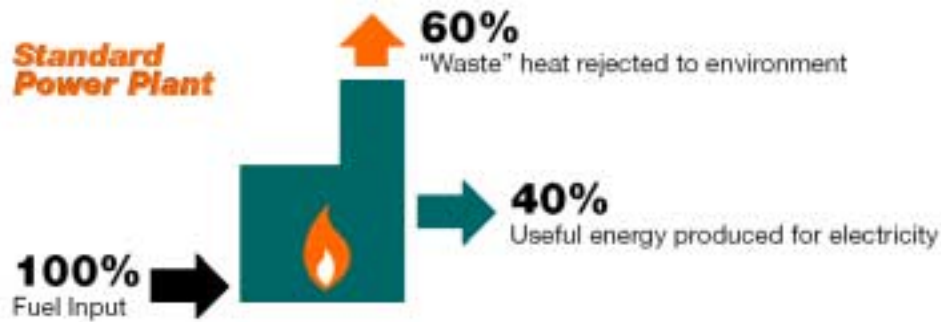

Figure 12: Schematic of the Typical Method Power Delivery in the United States Today

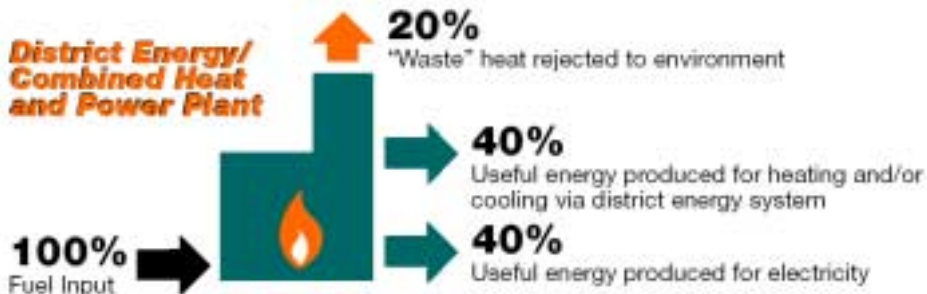

Figure 13: The Efficiency Advantages of Cooling, Heating, and Power

By productively using the “waste” heat from electric generation, the overall efficiency of energy delivery to the customer can significantly improve. However, transporting this heat for long distances is expensive. One solution is to move the generator nearer to the customer. New CHP for Building technology now makes this possible. (Diagram Courtesy of the Department of Energy)

Two-thirds of all the fuel used to make electricity in the U.S. is generally wasted by venting unused thermal energy, from power generation equipment, into the air or discharging into

water streams. While there have been impressive energy efficiency gains in other sectors of the economy since the oil price shocks of the 1970's, the average efficiency of power generation within the U.S. has remained around 33% since 1960.

Integrated systems for cooling, heating and power (CHP) systems significantly increase the efficiency of energy utilization, up to 85%, by using thermal energy from power generation equipment for cooling, heating and humidity control systems. These systems are located at or near the building using power and space conditioning.

Commercial buildings, college campuses, hospital complexes, and government facilities are good candidates for benefiting from integrated systems for CHP for buildings.

BCHP System Benefits

Reduced energy costs

Building owners can reduce their energy costs by deploying BCHP systems because compared to conventional systems these systems provide the following advantages:

- Increased energy efficiency
- Reduced demand charge
- Reduced peak electric energy costs

BCHP systems offer much higher energy efficiency than conventional stand-alone equipment for a similar degree of power reliability, comfort cooling, heating and indoor air quality. Because of the higher energy efficiency of the BCHP system, it consumes up to 47% less fuel than conventional systems. The reduced fuel consumption significantly reduces energy cost.

The cost of electricity to buildings is generally based on power demand (measured in kW) and electric energy usage (measured in kWh). Power demand charge is generally a monthly charge (\$/kW) based on the peak/maximum power used during a month for a specified period, generally 15 minutes to 30 minutes. Power demand charge rate can vary with time-of-year. BCHP systems reduce power demand in two ways: 1) by generating some of the power at site, and 2) by using thermal energy from power generation equipment, instead of electricity, for operating cooling, heating and/or humidity control equipment.

The charge for electric energy usage generally varies with the time-of-year and the time-of-day. This charge is the highest during peak periods, generally from 9AM until 3PM, and the least during off-peak period, generally from midnight till 7AM. Therefore, primary reduction in electric energy cost savings for using BCHP systems comes from avoiding purchase of electric energy during peak periods.

Improved Power Reliability

Economic losses due to power outages in the U.S. have cost American businesses billions of dollars. Since BCHP systems generate power on-site or near-site, these systems improve

power reliability by reducing the buildings dependency on the electric power grid, and by providing an additional power option to the building. Also because BCHP systems are located at or near a building, power outages experienced because of losing a distribution line are improbable. The greater number of buildings that use BCHP, the lower the demand on the electric grid will occur. In areas where the grid is at or near capacity, the reduced demand provided by BCHP will result in increased grid reliability.

Improved Economics for Enhancing Indoor Air Quality

Controlling indoor humidity is essential in enhancing indoor air quality in buildings. It is important to keep humidity in the indoor air to below 60% to prevent growth of mold, mildew and bacteria. Desiccant systems can control indoor humidity more effectively than conventional systems. In addition, desiccant systems can be driven by low temperature heat, such as the heat available from the exhaust gases of power generation equipment. This can provide enhancing indoor air quality at very low operating costs.

Reduced Life-Cycle Costs

The initial cost of BCHP systems for buildings is higher than purchasing electric power and using conventional chillers and boilers. However, the life-cycle cost of the BCHP systems is often lower because of the energy cost savings over its useful life of more than 20 years.

Attractive Return on Investment

BCHP systems reduce energy costs for buildings. If the incremental installed cost of BCHP systems over conventional systems is viewed as an investment, the return annual cost savings is often very attractive.

BCHP Technology

Power Generation Equipment

Technologies commercially available for generating electric power or mechanical shaft power on-site or near the site where the power is used include:

- Combustion turbines
- Engines
- Fuel Cells

Combustion turbines

Combustion turbines are a class of electricity generation devices that use natural gas or fuel oil to produce high-temperature; high-pressure gas to induce shaft rotation by impingement of the gas on a series of specially designed blades. Many turbines also use a heat exchanger called a recuperator for utilizing some of the thermal energy in the turbine exhaust heat for preheating the air/fuel mixture for the combustor section of the combustion turbine system.

The efficiency of electric power generation for combustion turbine systems, operating in a simple-cycle mode (i.e., without external use of heat in the turbine exhaust), range from 21 to 40 percent. Combustion turbines produce high quality heat that can be used to generate steam and hot water for other applications, including heating and cooling (using absorption chillers).

Utilization of thermal energy in the combustion turbine exhaust significantly enhances the efficiency of energy utilization. Maintenance costs per unit of power output for combustion turbines are among the lowest of all power generating technologies.

Power output rating of all combustion turbines is based on inlet temperature of 59°F. Output capacity of these turbines decreases with increase in ambient air temperature. Therefore, in hot weather climates or on hot days, cooling of turbine inlet air has been found to be cost effective for many power plants for boosting power output.

Three types of combustion turbines are commercially available:

- Industrial turbines
- Mini turbines
- Micro turbines

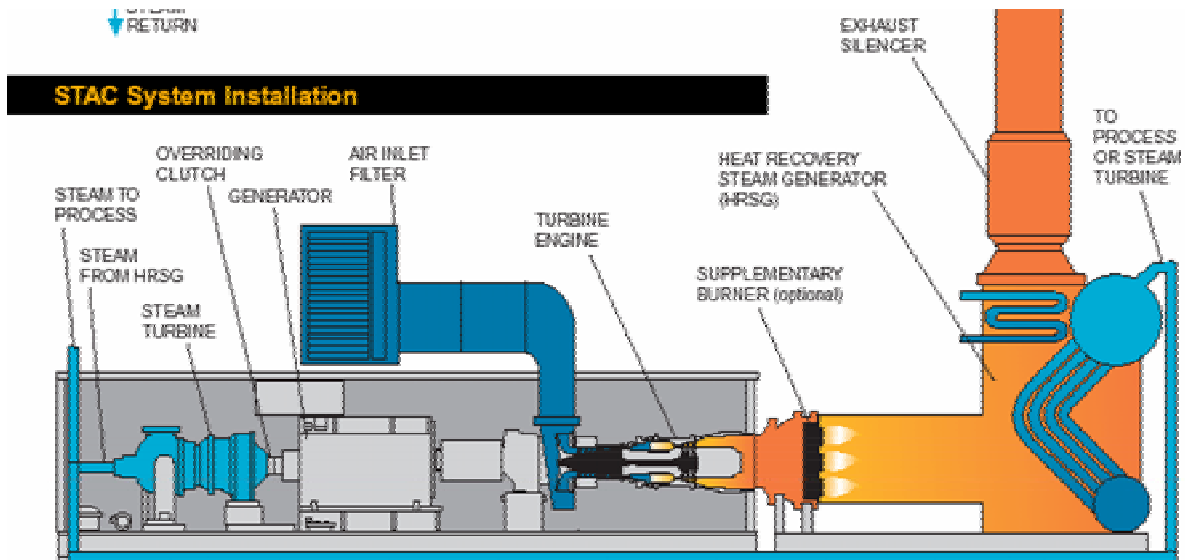

Figure 14: Schematic of an Industrial Gas Turbine Generator Set
(Diagram Courtesy of Solar Turbines)

Industrial turbines represent one of the well-established technologies for power generation. These turbines also represent "high" end of power generating capacity equipment. These can provide 1 MW to more 100 MW of electric power. Most CHP systems need capacities below 20 MW, enough for large office buildings, hospitals, or small campuses of offices and commercial buildings.

Mini and micro turbines are the newer generation of smaller turbines. The capacities of mini turbines range from 100 kW to 1000 kW and micro turbines range in capacities from 25 kW to 100 kW. It is not uncommon to ignore the differentiation between mini- and micro-turbines. For the purpose of discussion at this Web site all turbines smaller in capacity than 1MW will be referred to as microturbines.



Figure 15: Microturbine Installation
(Photo Courtesy of Capstone Microturbine Corp.)

These turbines can use natural gas, propane, and gases produced from landfills, sewage treatment facilities, and animal waste processing plants as a primary fuel. The fuel source versatility of microturbines allows their application in remote areas.

Microturbines evolved from automotive and truck turbochargers, auxiliary power units for airplanes, and small jet engines used on pilotless military aircraft. Microturbines have far fewer moving parts than conventional generating equipment of similar capacity. Therefore, these machines have the potential to significantly reduce maintenance and operating costs.

By using recuperators, existing microturbine systems are capable of energy efficiencies in the 25-30 percent range. These turbines have a tremendous potential for on-site power generation for CHP systems.

Engines

The use of a reciprocating engine, either 4-cycle internal combustion or diesel, is for producing mechanical shaft power. The shaft power can be used to operate a generator to produce electric power. It can also be used to operate other equipment, including a refrigerant compressor for process or space cooling. Both of these applications of engines are very well known and widespread. Engines can use natural gas, propane or diesel fuel and are available in capacities ranging from 5 kW to 10 MW.

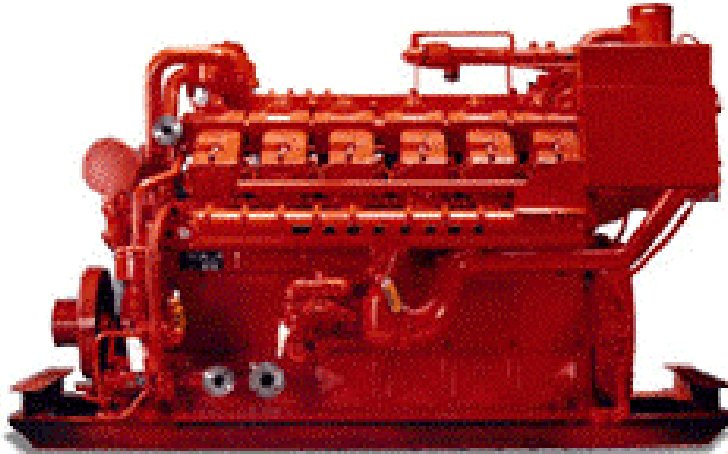

Figure 16: Typical Industrial Engine
(Photo Courtesy of Caterpillar Corp.)

Reciprocating engines for power generation are low capital cost, easy startup, proven reliability, good load-following characteristics, and heat recovery potential. Reciprocating, or piston-driven, engines are the fastest selling distributed generation technology in the world today. Existing engines achieve efficiencies in the range of 30 percent to over 40 percent. The incorporation of exhaust catalysts and better combustion design and control has significantly reduced pollutant emissions over the past several years.



Figure 17: Engine Generating Plant

Thermal energy in the engine exhaust gases and from the engine cooling system can be employed to provide space heating, hot water, or to power some absorption and desiccant equipment.

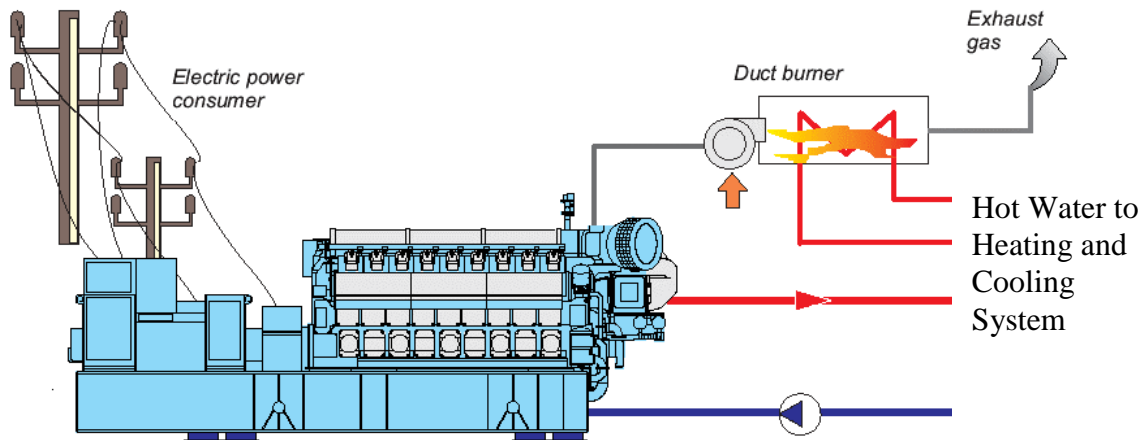

Figure 18: Engine System with Heat Recovery

Duct burner is used for exhaust No_x clean-up. A heat recovery muffler is used when emissions reduction is not required (Diagram Courtesy of the University of Illinois)

Operating efficiencies of engines tend to be somewhat lower and emissions are higher than microturbines and fuel cells. In some locations, depending on local air quality standards, engine emissions may limit its applications for BCHP systems.

Power Generation - Installed Costs

Combustion Turbine Generator Sets	
Capacity, kW	Installed Cost
600 kW	\$2,300 /kW
1,500 kW	\$2,000 /kW
2,000 kW	\$1,500 /kW
3,000 kW	\$1,100 /kW
4,000 kW	\$750 /kW
14,000 kW	\$600 /kW
27,000 kW	\$450 /kW
Reciprocating Engine Generator Sets	
500 kW	\$1,000 /kW
1,200 kW	\$800 /kW
4,000 kW	\$650 /kW

Table 2: Installed Costs of Turbine and Engine Generator Sets
Installed costs per kilowatt for combustion turbine and reciprocating engines generator sets represented in table.

Various manufacturers confirm that the downward trend in installed capacity cost continues. The current installed capacity cost for microturbines is between \$1500/kW to \$3000/kW. Manufacturers expected this number to drop to \$1000/kW just over the next three years. This, however, is in the competitive range of larger combustion turbine facilities or reciprocating engine plants.

Fuel cells

Fuel cells produce electric power by electrochemical reactions between hydrogen and oxygen without the combustion processes. Unlike turbines and engine generator sets, fuel cells have no moving parts and thus no mechanical inefficiencies.



Figure 19: Fuel Cell Package
(Photograph Courtesy of ONSI)

Phosphoric acid fuel cells (PAFCs) are commercially available. More than two hundred PAFC units, most in the size range of 200kW, are operating worldwide. PAFCs are realizing efficiencies over 40%.

The only byproducts of PAFC operation are water and heat. However, hydrogen fuel is produced by subjecting hydrocarbon resources (natural gas or fuels) to steam under pressure (called reforming or gasification); a process that often requires combustion and consequently environmental emissions.

Even though a fuel cell produces direct current (DC), it comes in a complete package in which the fuel cell is integrated with an inverter to convert the direct current to an alternating current (AC).

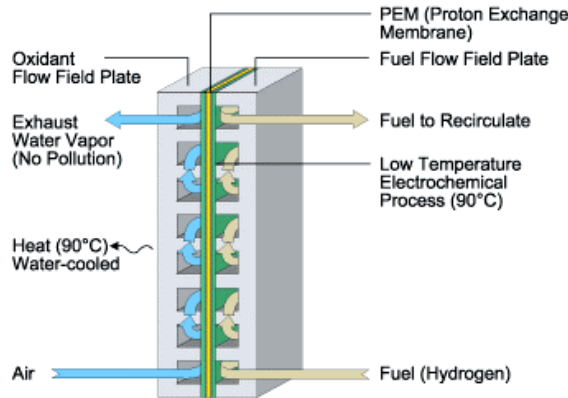

Figure 20: Operation of a PEM Fuel Cell
 (Diagram Courtesy of the Department of Energy)

There are three other types of fuel cells: proton exchange membranes (PEM), molten carbonate (MCFC), and solid oxide (SOFC). These fuel cells are at various stages of technology demonstration and are not commercially available. Each type of fuel cell has its own "preferred" range of capacities and waste heat temperatures that determine where they can be used to best advantage in BCHP systems.

Power Generation Equipment Suppliers

Supplier	Capacity Range, kW
Alstom	> 23,000 MW
E-Turbines, Inc.	
FiatAvio	20,000 – 230,000
General Electric	> 14,000
International Energy Systems	
Kawasaki Motor Corp.	1,500 – 7,000
Rolls-Royce Energy Systems	
Siemens Westinghouse	
Solar Turbines	1,000 – 50,000

Table 3: Suppliers of Industrial Combustion Turbines

Supplier	Capacity Range, kW
Capstone Turbine	30 - 60
Ingersoll-Rand Company	30-250 kW
Elliott/Bowman	45-65 kW

Table 4: Suppliers and Developers of Microturbines

Supplier	Capacity Range, kW
Caterpillar	100 - 3,000
Cooper Energy Services	350-6,500
Fairbanks Morse Engine Division	1,200 - 21,400
Genergy Power Solutions	60 - 2,000
Hess Microgen	85- 450
International Power Technology	<15,000
Jenbacher Energiesysteme	250 - 2,000
MAN Diesel	400 - 51,500
Mirrlees Blackstone, Inc.	600 - 10,000
Rolls-Royce Energy	3,000- 51,000
Tecogen	60-75
Wabash Power Equipment	60 - 100,000
Wärtsilä Diesel	300 -16,000
Waukesha Engine Div.	75 - 2,400

Table 5: Suppliers of Large Engines and Engine Generators

Technology	Supplier	Capacity Range, kW
Phosphoric Acid Fuel Cell (PAFC)	ONSI Corporation	200 kW
Proton Exchange Fuel Cell (PEMFC)	Plug Power, LLC	
Proton Exchange Fuel Cell (PEMFC)	Ballard Corporation	

Table 6: Suppliers and Developers of Fuel Cells

Productively Using Waste Heat - Thermally Activated Equipment

Gas Engine-Driven Chillers

In a gas engine-driven chiller, the engine produces mechanical shaft power that is used for operating a refrigeration compressor. This chiller is very similar to a conventional electric chiller. The only difference is that an electric motor that drives a refrigeration compressor in an electric chiller is replaced with a gas engine.



Figure 21: Typical Engine Chiller
(Photograph Courtesy of York International)

Absorption chillers

Absorption chillers are cooling machines that use heat energy for driving an absorption refrigeration cycle. These chillers require very little electric power (0.02 kW/ton) compared to electric chillers that need 0.5 to 0.88 kW/ton. Absorption chillers have fewer and smaller moving parts and are quieter than electric chillers. These chillers are also environmentally friendly by using water as a “natural” refrigerant.



Figure 22: Large Absorption Operating on Waste Heat from Engine Generators
Equipment Located at the University of Illinois at Chicago Power Plant (Photo Courtesy of the University of Illinois at Chicago.)

Commercially available absorption chillers can utilize one of the four sources of heat:

- Steam
- Hot water
- Exhaust gases
- Direct combustion

Absorption chillers are excellent candidates for providing some, or all, of the cooling in a BCHP system building. Modern absorption chillers feature new electronic controls that provide quick start-up, automatic purge and greater turndown capability than many electric chillers. Maintenance contracts and extended warranties are also available on absorption chillers at costs similar to those for electric chillers.

Most importantly, absorption chillers can be driven by low temperature heat, such as the heat available from power generation equipment. This both provides cooling driven by generator waste heat for high overall system efficiency AND reduces the maximum power requirements of most buildings, reducing the size and cost of the on-site generator.

Cooling Installed Costs

Chiller Size =	Installed Cost of Equipment		
	300 RT	500 RT	1000 RT
Installed Costs			
Electric Centrifugal	\$340/Ton	\$340/Ton	\$350/Ton
Single Stage Absorber	\$520/Ton	\$430/Ton	\$365/Ton
Double Effect Direct Fired Absorption	\$625/Ton	\$625/Ton	\$625/Ton

Table 7: Installed Costs of Electric and Absorption Chillers
The installed costs of electric centrifugal, single stage absorber, and double effect direct fired absorption chillers per ton shown in table. (Source: ORNL-funded Study by TA Engineering, Inc. for AGCC, June 2001)

Desiccant dehumidifiers

There are two separate aspects of space conditioning for comfort cooling;

1. Lowering the temperature of the air (sensible cooling), and
2. Reducing humidity in the air (latent cooling)

It is important to control humidity to below 60% to prevent growth of mold, bacteria and other harmful microorganisms in buildings and prevent adverse health effects.

Traditionally, cooling and dehumidification have been accomplished using a single cooling coil that lowers the air temperature below the dew point temperature. Moisture in the incoming air condenses on the cooling coil. To remove enough moisture often requires cooling air below the comfortable level and reheating.

Desiccant dehumidifiers reduce humidity in the air by using a desiccant material to attract and hold moisture. Desiccants can dehumidify independently of sensible cooling.

Recoverable heat from the exhaust gases of turbines and engines for power generation or engine-driven chillers can be used for regenerating desiccant material in these dehumidifiers.

In a BCHP system, it might be desirable to first reduce moisture content of the air using a desiccant dehumidifier and then cool the dehumidified air by using chillers. By reducing moisture content of the air, desiccant dehumidifiers take care of the latent cooling load and reduce the total cooling load on the chillers.



Figure 23: Desiccant Dehumidifier Operating at the University of Maryland
(Photo Courtesy of the Department of Energy)

Thermally-Activated Equipment Suppliers

Supplier	Capacity Range, RT
Alturdyne Energy Systems	25-4,000
Goettl Air Conditioning Inc.	10-25
Tecogen	30-1,000
The Trane Company	100-3,000
York International	350-2,000

Table 8: Suppliers of Engine Chillers

Supplier	Capacity Range, RT
Broad USA	100-2,600
Carrier Corporation	100-1,700
Trane Co.	400-2000
Dunham-Bush, Inc.	100-1,400
McQuay International	100-1,500
Robur Corporation	3-25
Cooling Technologies	5-25
Thermax USA	
Yazaki Energy Systems	10-100
York International	120-1,500

Table 9: Suppliers of Absorption Chillers

Supplier	Capacity Range, CFM
Kathabar	1,000-84,000
Bry-Air Inc.	
Munters Corporation	
Seibu Giken	

Table 10: Suppliers of Desiccant Systems

Supplier	Capacity Range, kW
Alstom	
Dresser Rand	
E-Turbines, Inc.	
Turbo Steam, Inc.	100-5,000
General Electric	> 14,000
International Power Technology	< 14,000
Murray Turbomachinery	
MTI Turbomachinery	
Siemens Westinghouse	

Table 11: Suppliers of Steam Turbines