

SHANDS HOSPITAL

4.3 MW COMBUSTION TURBINE

CHP FACTS

Location:

University of Florida

Generation Equipment:

- 4.3 MW Combustion Turbine
- 14,500 lb/hr Heat Recovery Steam Generator
- 1,200 ton Steam Turbine Centrifugal Chiller
- Combustion Turbine Inlet Cooling
- 30,000 lb/hr Packaged Boiler
- Two 1,500 Electric Centrifugal Chillers

Output:

4.3 MW

Installation Date:

2008

Installation Cost:

\$45 million

Fuel:

Natural Gas



PROJECT OVERVIEW

Shands HealthCare Cancer hospital is located on the University of Florida campus. Shands selected Gainesville Regional Utilities (GRU) to design and build an on-site energy center for the hospital. Shands wanted to insure reliability and quality of power due to the nature of digital hospital equipment that is sensitive to power quality.

The on-site energy center will be comprised of a CHP system that delivers district heating and cooling to the hospital as well as reliable power. The facility uses a combustion turbine for the prime

mover, producing 4.3 MW of electricity while the heat recovery steam generator provides steam for the building and aids with the production of chilled water. The 4.3 MW natural gas turbine provides 100% of the hospitals electric and thermal needs. This allows the site to operate at a total thermal efficiency of 75%.



PREPARED FOR
UNITED STATES

DOE

CHP OPERATION

This high efficiency, low emissions CHP system was designed and built for the hospital which can run in parallel with the grid, and can also run in island mode. The system was built to LEED standards.

Building the dedicated power station near the hospital assures smooth and continuous power to the hospital's essential devices. Two electrical feeds allow for double redundancy, and emergency black start generators provide additional back up.

LOWER EMISSIONS

Gainesville Regional Utilities compared the emissions with other power plants in the area and observed a reduction in environmental impact.

- Carbon Dioxide: 68% reduction
- Sulphur Oxide: 99% reduction
- NOx: 98% reduction

SOURCE

Hybrid CHP Energy Center Case Study, Recycling Energy

SYSTEM COMPONENTS

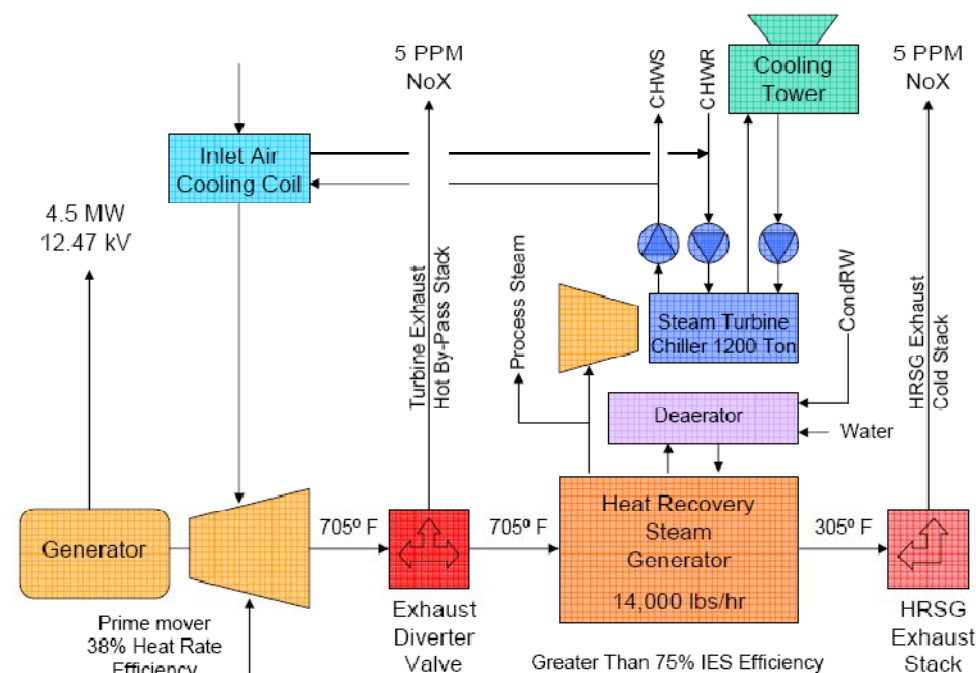

HRSG – Heat Recovery Steam Generator
 CondRW – Condensate Return Water
 CHWS – Chilled Water Source
 CHWR – Chilled Water Return

SOUTHEAST CHP
 APPLICATION CENTER
 WWW.CHPCENTERSE.ORG